

XGTC65 Telescopic Crawler Crane



RONCO GROUP





CONTENTS

P02	• Product Highlights
	• Main technical parameters
P11	• Lifting performance table
P15	• Transport plan

02

XGTC65 CRAWLER CRANE

- Product Highlights
- Main technical parameters

Highlights of XGTC65 telescopic crawler crane

01 Strong lifting capacity and wide operating range outperforms counterparts

(1) Five U-shaped boom sections, with dual cylinder rope row telescoping, single-plate type boom head, compact boom butt and inserted slide block. The overlapping length is improved, the lifting capacity is the highest in the industry, which is at least 15% higher than competitors. Its performance in typical working conditions is comparable to 75 tonnage cranes in the industry.

(2) Boom length is 12m ~ 46.5m, jib length is 9.5/16m, boom combination length is leading in the industry and is comparable to 80 tonnage cranes. It can meet the requirements of different working radius.

(3) Arbitrary telescoping of main boom: boom combination has been increased from 7 to 15 kinds, with richer working condition and higher boom length switching efficiency, which greatly improves the performance and adaptability of medium & long boom.

02 Rapid working speed, strong mobility and high working efficiency

(1) Leading operation speed satisfies the requirement of quick load lifting (high/low travel speed, lifting speed).

(2) Working conditions of travel with no-load, static lifting, travel with load, etc, it is flexible and can meet the needs of different constructions.

(3) Telescopic crawler tracks meet the requirements on machine size when passing narrow space (minimum width for passing is 3.4m).

03 Multiple transport modes with high economy

(1) Max. weight of single unit (counterweight and track frame are removed) in transport state is 30.6t, transport dimension is 14.3 × 2.99 × 2.91m, the transport width is less than 3m, meeting the latest road transport regulations in China;

(2) Multiple transport modes. Overall crane transport (counterweight and track frame are not removed); crane transport with track frame (remove counterweight); crane transport after removing counterweight and track frame. All above modes meet the local transportation laws and regulations.

(3) Load charts for four kinds of counterweight combinations are provided for this crane, reducing the transportation cost. The crane has four counterweight combinations (0 ~ 19.5t) for users to choose according to the actual lifting requirements.

04 Full self-assembly and disassembly, high assembly efficiency

Full self-assembly and disassembly is realized for the overall crane, the track frames and counterweight can be installed and dismantled without the use of auxiliary crane, which can reduce the use cost.

(1) "Assembly working condition" with independent lifting capacity tables, and outrigger cylinders are equipped for crane undercarriage to realize the self-assembly and disassembly of crawler tracks.

(2) Self-assembly/ disassembly system (lifting cylinder + pin shaft cylinder) and remote controller (realize the free change between the synchronous and separate control of counterweight lifting cylinder) are configured to realize the self-assembly and disassembly of counterweight, thus reducing the operation intensity and use cost.

05 It can sustain long-time and high power work, high product utilization rate

The effective capacity of fuel tank is up to 440L (10% higher than competitors), which can effectively guarantee continuous lifting operation. The large power independent cooling system can ensure that the engine and hydraulic system can work for a long time with high power and not produce too high temperature.

06 Large track gauge chassis with high strength, good stability and large drive force

The crane adopts special designed large track gauge chassis structure; wheel span reaches 4200mm, the stability is good. The width of track shoe is 760mm, the ground pressure is 0.08MPa; the height of chassis off ground is high with good mobility. The travel gear adopts large torque travel motor (usually for 75t crane), with large driving force and strong climbing ability, which is more suitable for complex road conditions.

07 Complete safety devices provide comprehensive protection

(1) Various protective measures against overload, over-wind, over-release and over-extend, etc. provide safe and reliable operation;

(2) In travel operation, set functions such as high speed travel with empty load, automatic deceleration during high speed travel with heavy load, with good active safety.

08 User-friendly design provides comfortable operation and convenient maintenance

(1) New modeling cab (the keys in the cab are upgraded to integrated keys, with higher reliability). It is equipped with catwalk, hood, ladder and maintenance passage to improve the operation and maintenance comfort; the cab can be tilted upward (independent tilting bracket, can tilt 15°) to observe the work at high position; Air conditioning is also equipped to provide comfortable operation experience.

(2) The control system is equipped with virtual wall and remote management function, which makes the product intelligent and has high safety in extreme working conditions.

Product components and system description

Superstructure

01 Engine

Weichai engine WP7G270, the emission of the engine meets off-road China stage III and EU Stage III standard, rated power/speed: 199kW/2000rpm, with a large power margin, which is more suitable for muddy road conditions in foundation construction.

02 Hoist gear

Hoist gear description:

Lifting speed with no load: 0 ~ 140m/min.

Main and auxiliary winch rope diameter: 18mm, single line pull is 5.6t.

03 Luffing gear

Description: front luffing with single cylinder

Boom raising time ≤ 45s

04 Slewing gear

Driven by motor, the planetary reducer is externally meshed with slewing bearing. Newly designed slewing buffer valve makes the start and stop more stable.

Slewing bearing: with strong bearing capacity, ensures the 360° slewing operation safe and stable.

Slewing speed: 0 ~ 2.0r/min

05 Electrical control system

The system adopts WIKA (Hirschmann) integrated control system, which consists of engine control, safety control, pilot control, LMI control and auxiliary function control.

The control system is equipped with boom arbitrary telescoping function, virtual wall and remote management function. The product is intelligent and has high safety under extreme conditions; CAN-bus transmission and display interface to query port status (monitor all BUS sensors), making it easier for troubleshooting. Shrapnel terminals and heavy loads are used to improve the convenience of maintenance.

The monitoring system on winch and turntable rear side improves the operating comfort and safety.

06 Hydraulic system

Hydraulic pilot proportional open control system, equipped with independent high-power cooler, large capacity hydraulic oil tank (capacity 900L, 12% larger than competitors), more suitable for foundation construction, which can ensure the stable operating temperature of the system.

The key components are imported from first-line brands (Linde main pump + Rexroth motor + Bucher balance valve), with high product reliability.

Key fittings adopt imported first-line brands (Linde main pump + Rexroth MADA + Bucher balance valve), with high reliability.

05 Hook block

The effective capacity of fuel tank is up to 440L (10% higher than competitors), which can effectively guarantee continuous lifting operation. The large power independent cooling system can ensure that the engine and hydraulic system can work for a long time with high power and not produce too high temperature.

Name	60t hook block	25t hook block	5t hook block
Weight (Kg)	520	315	93
Quantity	1	1	1

06 Counterweight

Turntable counterweight is composed of one 6t counterweight block, one 5.5t counterweight block and two 4.0t counterweight blocks, among which 6t and 5.5t counterweight blocks are the same model with XGC55T crawler crane. Turntable counterweight has four kinds of combination, see the table below for details:

Turntable counterweight combination:

No.	Turntable counterweight weight(t)	Turntable counterweight combination
1	0	0 (counterweight is not installed)
2	6	6
3	11.5	6+5.5
4	19.5	6+5.5+4.0+4.0

Product components and system description

Undercarriage

- 01** **Crawler track extension/retraction**
Crawler track extension and retraction is realized through the crawler track telescoping cylinder. It is convenient for site transfer and narrow space travel. It is the only one of the same tonnage crane in the industry with outrigger cylinder, which is more suitable for the change of track gauge in muddy road conditions, easy and efficient.
- 02** **Travel device**
Straight travel and turning are realized by travel motor, reducer and drive sprocket. The travel speed with empty load is 0~2.4km/h while the travel speed with load is 0~1.0km/h; the grade ability is 45%.
- 03** **Crawler shoe**
Adopt the crawler shoes which are especially used for excavators. It has stronger gripping ability and is more suitable for traveling on "soft" ground.
The track rollers and carrier rollers have self-lubricating and maintenance-free functions.

Safety devices

- 01** **Emergency stop button**
Press the emergency stop switch to shut off the engine and stop the crane.
- 02** **Pilot control switch**
The electrical system for lifting operation cannot work normally until the switch is pressed.
- 03** **LMI**
LMI will send signal and restrict the dangerous movement when the lifting weight exceeds the rated lifting capacity or boom/jib angle and radius exceed the rated range.
- 04** **Hoist height limiter**
It consists of boom and jib top limit switch and weight. When the hook center is lifted to about 710mm from boom pulley center, the lifting movement will be stopped automatically.
- 05** **Level gauge**
As a real-time display with high accuracy, the level gauge will show the crane tilting angle and provide prompt for the safe working environment of the ground.
- 06** **Slewing locking device**
It ensures that the turntable is effectively locked during transport to prevent free swing.
- 07** **Rope end limiter**
The hook block will stop lowering automatically when there are only 3~5 loops of rope left.
- 08** **Monitoring system**
Winch and turntable (rear side) monitoring system and optional data recorder are equipped to query the running state of the crane in rear time.

Note: the above configuration is based on the specific order contract.

Main technical parameters

Type	Items	Unit	Data	Permissible allowance	
Dimension	Overall crane length	mm	14616	±1%	
	Overall crane width (extend/retract)	mm	4960/3400	-1%~0	
	Overall crane height	mm	3338	-1%~0	
	Central distance from drive roller to driven roller	mm	5368	±1%	
Weight	Track shoe width	mm	760	±1%	
	Total mass in travel state	kg	68000	±3%	
Travel	Max. travel speed with no load	km/h	2.4 (high speed)/1.0 (low speed)	±5%	
	Min. ground clearance	mm	429	±1%	
	Max. grade-ability (no load)	%	45	≤	
	Ground pressure	MPa	0.08	≤	
Power	Engine model	-	WP7	/	
	Engine rated power	kW	199	/	
	Engine rated speed	r/min	2000	/	
	Emission standard	-	Off-road China III/EU Stage III	/	
Volume	Hydraulic oil tank	L	900	±3%	
	Fuel tank	L	440	±3%	
Main performance	Max. rated lifting capacity	t	65	±5%	
	Max. load moment	Base boom	kN-m	2205	±5%
		Base boom	m	12	±1%
		Full-extend boom	m	46.5	±1%
		Full-extend boom +jib	m	62.5 (46+16.5)	±1%
	Jib offset angle	°	0°, 15°, 30°	±1°	
Working speed	Boom raising time (0~80°)	s	45	≤	
	Boom fully-extended time	s	90	≤	
	Max. slewing speed(base boom, no load)	r/min	2.0	≥	
	Hoisting speed (no load at the 4th layer)	Main winch	m/min	140	≥
Auxiliary winch		m/min	140	≥	
Transport	Max. mass of single unit in transport state	t	30.6	±3%	
	Max. dimension of single unit in transport state	m	14.3×2.99×2.91	±1%	

Notes:

1. Wire rope speed is the calculated value of the rope on the drum fourth layer with engine idle running, which changes according to different load and working conditions.
2. Travel speed, slewing speed and the grade-ability are the theoretical values for the crane based on level and solid ground (with basic boom).
3. We reserve the right to improve and update the technical specifications without prior further notice.

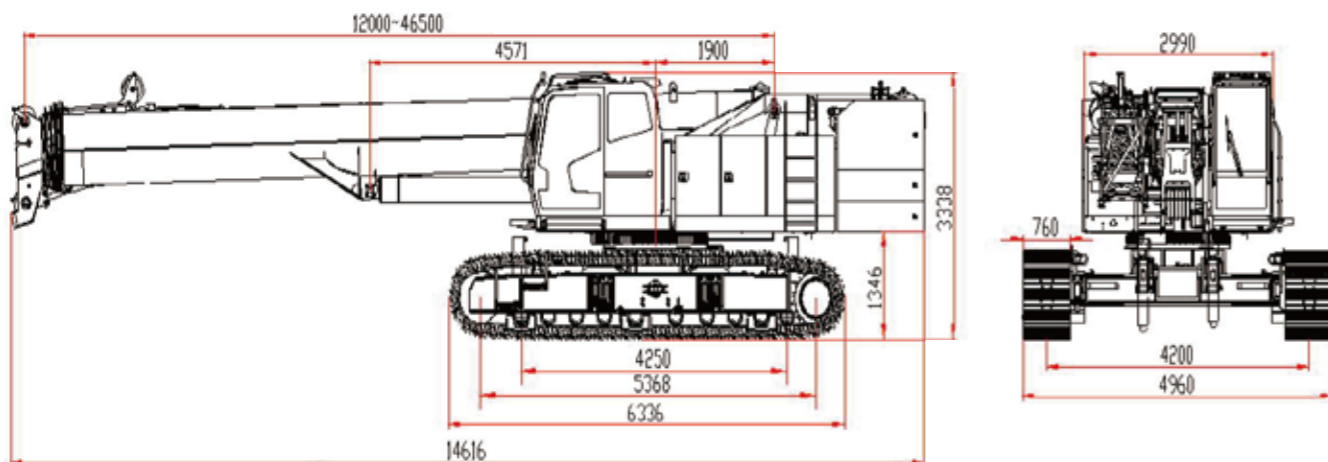

Items	Manufacturer			
Power system	Weichai			
Hydraulic system	Pump group	Main pump	Linde (imported, first-line brand)	
		Gear pump	Changjiang Hydraulic	
	Hoist winch	Main valve		Shengbang
		Motor	Rexroth Bosch (imported, first-line brand)	
		Balance valve	Rexroth Bosch (imported, first-line brand)	
		Reducer	Zhuzhou Gear	
	Slewing	Motor	Liyuan/Huade	
		Reducer	Shengbang/Zhuzhou Gear	
	Travel	Motor	Liyuan/Shanghai Electric	
		Reducer	Zhuzhou Gear	
	Luffing	Balance valve	Bucher (imported, first-line brand)	
		Oil radiator motor	Bucher (imported, first-line brand)	
Electrical system	LMI		Wika (Hirschmann)	
	Controller	Palfin (imported, first-line brand)		
Wire rope	Slewing bearing		Rothe Erde/Tongli	
	Main winch rope, aux. winch rope		Juli	
Self-assembly and disassembly	60t/25t/5t hook block		Standard configuration (unique in domestic industry)	
	Crawler track			
Cab tilting	Counterweight		Standard configuration	
	0~15°			
Outrigger cylinder	Assist the change of track gauge+ self-assembly		Standard configuration (unique in domestic industry)	
Monitoring system	Winch+ turntable tail		Standard configuration	
Level gauge	Turntable		Standard configuration	
Arbitrarily telescopic of main boom			Standard configuration	
Tool box	Chassis		Standard configuration	



XGTC65 CRAWLER CRANE

♦ Lifting performance table

(1) Main boom working condition: crawler tracks are fully extended, static loading, superstructure counterweight 19.5t, 360° working

Radius (m)	Boom length							
	12	16.3	18.5	20.6	22.8	24.9	27.1	29.3
3	65.0							
3.5	55.0	50.6						
4	51.5	50.6	30.2					
4.5	49.5	48.4	30.2	37.0	29.5	27.0		
5	45.0	45.4	30.2	36.5	29.5	27.0	29.5	24.6
6	37.2	36.4	30.2	33.6	29.5	25.3	29.5	24.6
7	29.3	28.9	30.1	26.9	27.7	23.7	25.3	24.6
8	23.2	23.1	24.9	21.9	22.8	22.0	20.9	21.2
9	18.8	18.8	20.9	18.3	19.3	19.9	17.6	18.0
10	14.0	15.6	17.6	15.5	16.5	17.2	15.0	15.5
12		11.1	13.0	11.0	12.6	13.4	11.4	11.9
14		8.0	10.0	8.1	9.6	10.7	8.9	9.5
16			7.7	5.9	7.4	8.6	7.0	7.7
18				4.3	5.8	6.9	5.5	6.4
20					4.5	5.7	4.3	5.3
22						4.6	3.3	4.2
24							2.4	3.4
26								2.7
28								
30								
32								
34								
36								
38								
40								
42								
Parts of line	12	10	8	8	6	6	6	5
The 2nd boom section	0%	50%	0%	100%	50%	0%	100%	50%
The 3rd boom section	0%	0%	25%	0%	25%	50%	25%	50%
The 4th boom section	0%	0%	25%	0%	25%	50%	25%	50%
The 5th boom section	0%	0%	25%	0%	25%	50%	25%	50%

Lifting performance table

Radius (m)	Boom length						
	31.4	33.6	35.7	37.9	40	42.2	46.5
6	18.2	24.9					
7	18.2	22.9	18.2	12.5			
8	17.0	19.0	17.1	12.5	16.5	12.0	
9	15.9	16.1	16.2	12.5	14.2	11.6	11.2
10	14.9	13.9	14.0	11.9	12.2	11.3	10.3
12	12.3	10.6	10.8	11.0	9.4	9.4	7.8
14	10.0	8.3	8.7	8.9	7.4	7.5	6.2
16	8.2	6.7	7.1	7.3	5.9	6.1	4.9
18	6.9	5.4	5.9	6.2	4.8	5.1	4.0
20	5.9	4.5	4.9	5.3	4.0	4.3	3.3
22	5.1	3.7	4.2	4.6	3.3	3.6	2.7
24	4.3	3.1	3.6	4.0	2.8	3.1	2.2
26	3.6	2.4	3.1	3.5	2.3	2.7	1.8
28	3.0	1.9	2.6	3.1	1.9	2.3	1.5
30		1.3	2.1	2.7	1.6	2.0	1.2
32			1.6	2.3	1.4	1.7	1.0
34				1.9		1.5	
36						1.2	
38							
40							
42							
Parts of line	5	5	4	4	4	3	3
The 2nd boom section	0%	100%	50%	0%	100%	50%	100%
The 3rd boom section	75%	50%	75%	100%	75%	100%	100%
The 4th boom section	75%	50%	75%	100%	75%	100%	100%
The 5th boom section	75%	50%	75%	100%	75%	100%	100%

(2) Fixed jib working condition: crawler tracks are fully extended, static loading, superstructure counterweight 19.5t, 360° working

Boom length, m	46.5					
	9.5			16		
Fixed jib length, m						
Boom angle/jib offset angle	0	15	30	0	15	30
80	5	3.5	3.0	3.0	2.5	1.8
78	5	3.5	3.0	3.0	2.4	1.7
75	4.8	3.4	2.8	2.9	2.2	1.5
72	4.5	3.2	2.6	2.8	2.0	1.4
70	4.2	3.0	2.5	2.6	1.8	1.3
65	3.4	2.8	2.3	2.4	1.6	1.3
60	2.3	2.2	2.1	1.5	1.4	1.2
55	1.5	1.5	1.5	0.9	0.8	0.9
50	1.1	1.0	1.0	0.5	0.4	0.5

Notes:

1. The unit of “radius” and “boom length” in above tables is “m” .
2. The given data in the table are the rated loads of crane on a solid and plane ground. The radii in the table are the actual radius after lifting.
3. There are three kinds of hook blocks, 60t (main boom working condition), 25t (main boom working condition), 5t (fixed jib working condition), the weight of hook blocks is as below:

Hook block	60t	25t	25t
Weight (kg)	520	315	315

15

XGTC65 CRAWLER CRANE

- Transport plan

Three transport plans for the basic machine are provided according to laws and regulations and the actual situation of the user.

1. Basic machine transport plan A (no part is removed, the crane is transported as a whole)

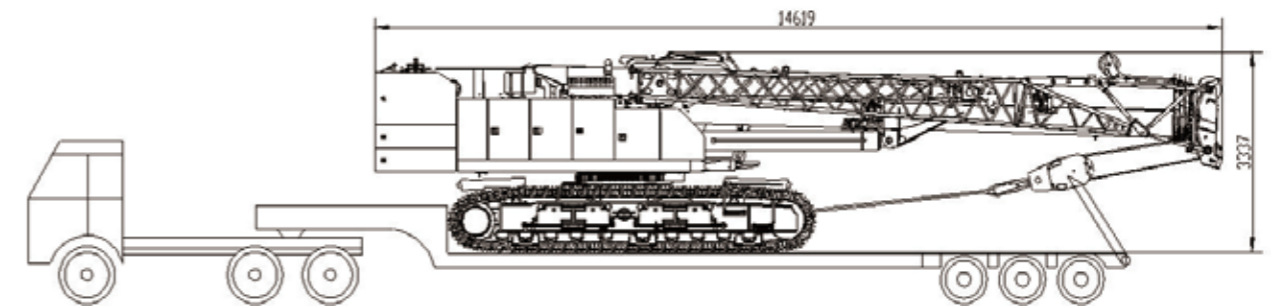

Weight (t)	Dimension (m)
68.4	14.62×3.36×3.34

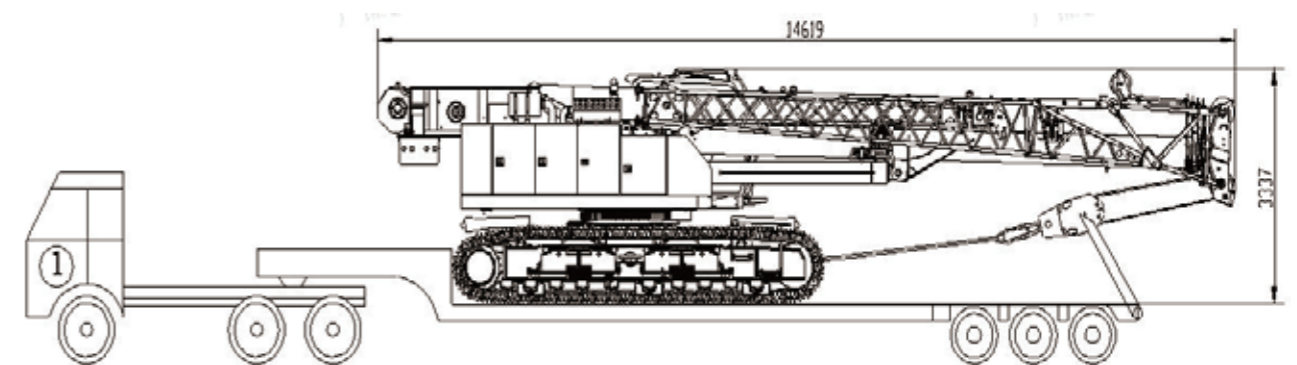

Weight (t)	Dimension (m)
48.9	14.619×3.36×3.337

Memos

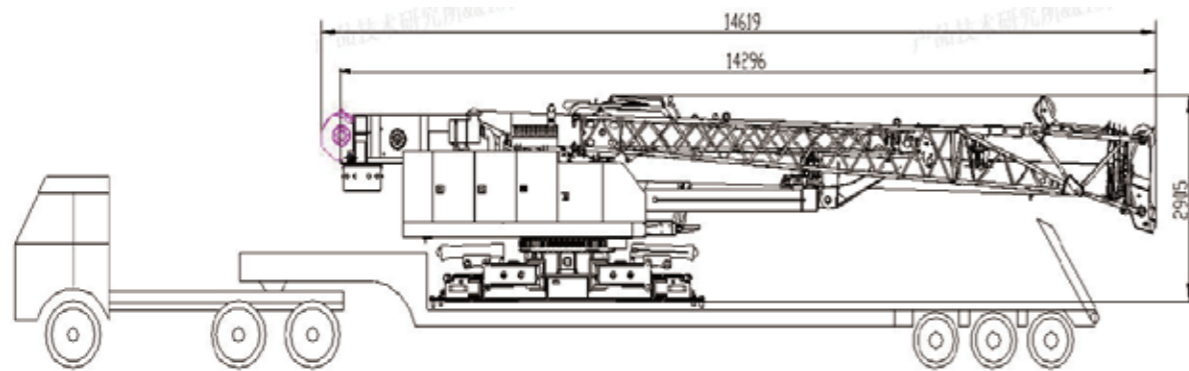

Weight (t)	Dimension (m)
30.6	14.296×2.9×3.337

Remarks:

1. Pad with wood blocks at the front and rear sides of crawler tracks to prevent sliding during transport.
2. The sizes in above figures are all design size, owing to manufacturing deviation, there might be difference.
3. The above transport sizes are not drawn in proportion, and the marked sizes are design values, package is not included.