

SLEW
SAFE
MOVE SAFE

TIDD
CRANE ||||



**Turning the corner on
crane operator safety**

Available in TIDD PC28

or

Retro Fit TIDD PC25

Slew Safe delivers peace of mind for drivers, dogman, crane owners and site owners, with improved safety, risk management and duty of care.

Slew Safe simply and effectively allows the TIDD PC28 and PC25 operator to pick and carry a load knowing that they will be warned and restricted. No other pick and carry crane is this safe.

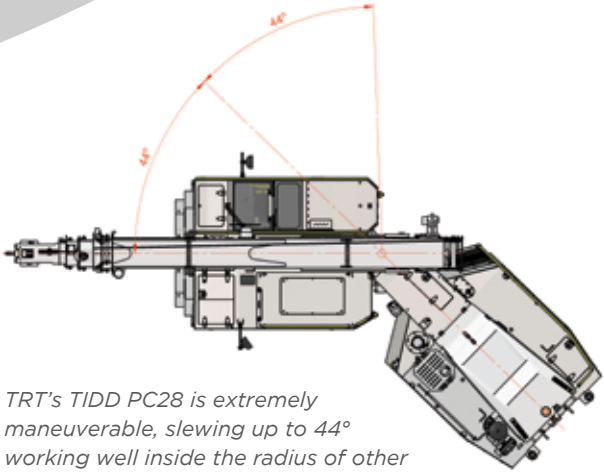

TRT's TIDD PC28 is extremely maneuverable, slewing up to 44° working well inside the radius of other pick and carry cranes in its class. At only 2.5m wide the PC28 has a smaller foot print, with Slew Safe it's now even safer!

This is the only pick and carry crane with this level of safety
Australian Innovation Patent No. 2019100317

TRT.
MADE
POSSIBLE

www.trt.co.nz

www.trtaustralia.com.au

How Slew Safe Works

When the crane in operation moves from green and amber to **RED**, this is an overload notification (based on the lifting chart). This will activate the Slew Safe.

When the crane is operated in the **GREEN** and **AMBER** areas of the lifting chart, Slew Safe will remain inactive.

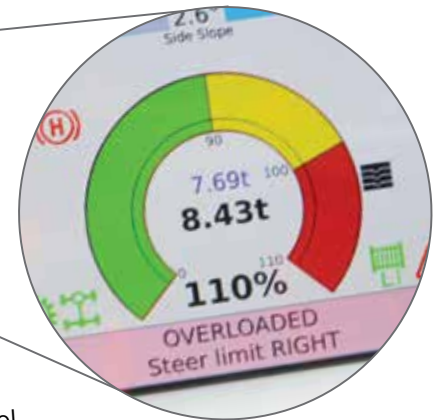

Activation of Slew Safe will:

- Reduces speed of the steering to 15% in the unsafe direction
- Makes steering harder with instant feedback through the steering wheel to operator
- The engine will "load up" making an audible sound change for operator
- Constant audible alarm inside and outside cabin to warn operator and dogman of overload
- Retains ability to move back to the safe direction for normal operation in **GREEN**

TIDD PC28 The Safest in its Class

Slew Safe is the latest innovation to turn the corner on crane safety!

Other safety features that make TIDD PC28 the safest pick and Carry Crane for your operation include:

- Higher operator position allowing better visibility.
- Superior stability with front hydraulic suspension.
- Dynamic LMI with a deadlock switch inside the cabin and bridging switch outside the cabin.
- ROPS Cabin with FOPS option and 150kg rated air suspension seats with 3-point integrated safety belts.
- ABS brakes.

Contact us for a copy of the new TIDD PC28 charts, manuals or the Slew Safe technical overview.



Available from:



Ronco Construction Equipment & Engineering

33 Valencia Way, Maddington WA 6109
P: 1800CRANES | (08) 9459 6212
E: tidd@ronco.com.au

www.ronco.com.au