



Construction Equipment & Engineering

Hook Loaders

CALL 1800CRANES



KEY FEATURES

Hyva Hook loaders are proven to deliver the very highest levels of flexibility, strength and reliability. Made with high yield steels, they offer real height and weight advantages, and can be supplied with various options to meet any requirement.

**International Market
Leader in Waste
Handling Equipment
and
Transport Solutions.**

HYVALIFT MOVES
YOUR WORLD

■ (08) 9459 6212 / 1800CRANES
■ 0436 307 679

■ www.ronco.com.au
■ hyva@ronco.com.au



Construction Equipment & Engineering

HookLift

Dimensions & Specifications

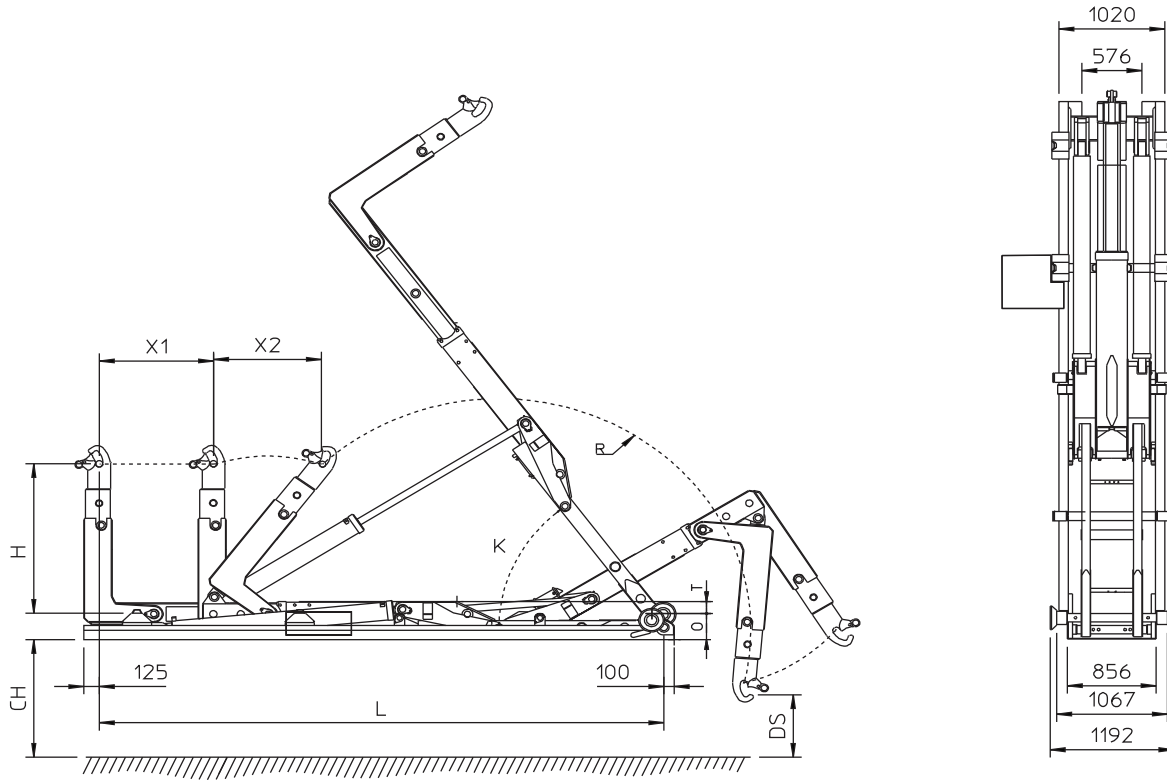

OVERALL DIMENSIONS

MODEL	8-36S	10-47S	16-53S	20-57S Optional 22 T	20-57 SK Optional 22 T	20-65 SK Optional 22 T
Lift Capacity kg	8,000 kg	10,000 kg	16,000 kg	20,000 kg	20,000 kg	20,000 kg
H (mm)	900	1450	1450 or 1570	1450 & 1570	1450 & 1570	1450 & 1570
X ¹ (mm)	800	1000	1000	1200	1300	1300
X ² (mm)	N/A	N/A	N/A	N/A	1050	1050
L (mm)	3600	4700	5350	5700	5850	6500
O (mm)	225	277	277	280	280	280
K	49°	50°	50°	47°	56°	51°
R (mm)	1828	2880	3045	3045	2455	2720
T (mm)	75	130	130	130	130	130
Weight ¹ (kg)	1114	1930	2080	2475	2900	3100
DS (mm)	749	1006	1167	1167	580	687
Bin length (mm)	3000-4600	3750 - 5800	4400 - 6550	4550 - 6800	3650 - 6800	4150 - 7600
Loading (sec)	-	28	34	40	49	52
Unloading (s)	-	35	44	50	65	68
Tip (time) ² (s)	-	30	39	43	51	55